

P-channel -30 V, 12 mΩ typ., -9 A, STripFET™ H6 Power MOSFET in an SO-8 package

Datasheet - production data

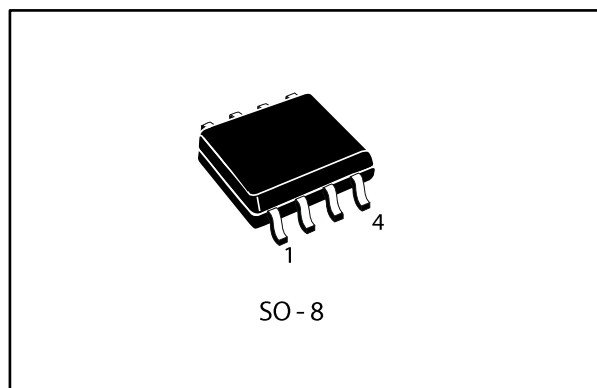

Figure 1: Internal schematic diagram

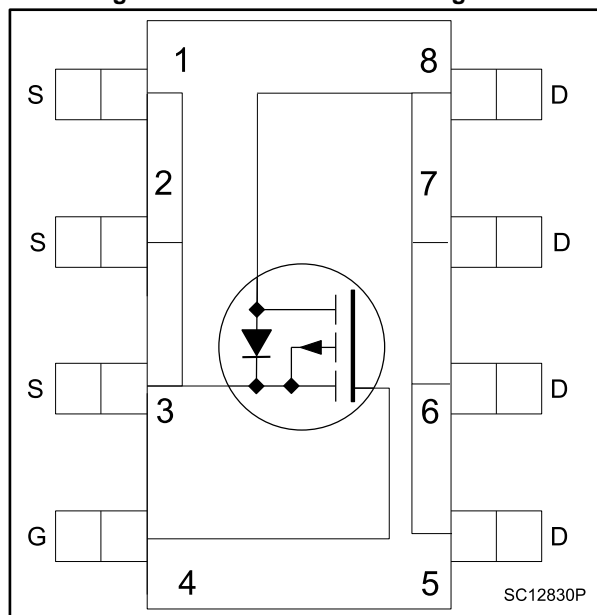

Table 1: Device summary

Order code	Marking	Packages	Packing
STS9P3LLH6	9K3L	SO-8	Tape and reel

Features

Order code	V _{DS}	R _{DS(on)} max	I _D
STS9P3LLH6	-30 V	15 mΩ	-9 A

- Very low on-resistance
- Very low gate charge
- High avalanche ruggedness
- Low gate drive power loss

Applications

- Switching applications

Description

This device is a P-channel Power MOSFET developed using the STripFET™ H6 technology with a new trench gate structure. The resulting Power MOSFET exhibits very low R_{DS(on)} in all packages.

Contents

1	Electrical ratings	3
2	Electrical characteristics	4
	2.1 Electrical characteristics (curves)	6
3	Test circuits	8
4	Package information	9
	4.1 SO-8 package information	9
	4.2 SO-8 packing information.....	11
5	Revision history	12

1 Electrical ratings

Table 2: Absolute maximum ratings

Symbol	Parameter	Value	Unit
V_{DS}	Drain-source voltage	-30	V
V_{GS}	Gate- source voltage	± 20	V
$I_D^{(1)}$	Drain current (continuous) at $T_{amb} = 25^\circ\text{C}$	-9	A
	Drain current (continuous) at $T_{amb} = 100^\circ\text{C}$	-5.6	
$I_{DM}^{(2)}$	Drain current (pulsed)	-36	A
$P_{TOT}^{(1)}$	Total dissipation at $T_{amb} = 25^\circ\text{C}$	2.7	W
T_{stg}	Storage temperature range	-55 to 150	$^\circ\text{C}$
T_j	Operating junction temperature range		

Notes:

⁽¹⁾This value is rated according to $R_{thj-amb}$

⁽²⁾Pulse width limited by safe operating area

Table 3: Thermal data

Symbol	Parameter	Value	Unit
$R_{thj-amb}^{(1)}$	Thermal resistance junction-amb	47	$^\circ\text{C}/\text{W}$

Notes:

⁽¹⁾When mounted on 1 inch² FR-4 board, 2 oz. Cu., $t \leq 10$ s

2 Electrical characteristics

($T_{CASE} = 25\text{ °C}$ unless otherwise specified)

Table 4: On/off states

Symbol	Parameter	Test conditions	Min.	Typ.	Max.	Unit
$V_{(BR)DSS}$	Drain-source breakdown voltage	$I_D = -1\text{ mA}$	-30			V
I_{DSS}	Zero gate voltage drain current ($V_{GS} = 0$)	$V_{DS} = -30\text{ V}$			-1	μA
		$V_{DS} = -30\text{ V}$, $T_C = 125\text{ °C}$ ⁽¹⁾			-10	μA
I_{GSS}	Gate-body leakage current ($V_{DS} = 0$)	$V_{GS} = \pm 20\text{ V}$			-100	nA
$V_{GS(th)}$	Gate threshold voltage	$V_{DS} = V_{GS}$, $I_D = -250\text{ }\mu\text{A}$	-1		-2	V
$R_{DS(on)}$	Static drain-source on-resistance	$V_{GS} = -10\text{ V}$, $I_D = -4.5\text{ A}$		12	15	$\text{m}\Omega$
		$V_{GS} = -4.5\text{ V}$, $I_D = -4.5\text{ A}$		18	22.5	$\text{m}\Omega$

Notes:

⁽¹⁾Defined by design, not subject to production test.

Table 5: Dynamic

Symbol	Parameter	Test conditions	Min.	Typ.	Max.	Unit
C_{ISS}	Input capacitance	$V_{DS} = -25\text{ V}$, $f = 1\text{ MHz}$, $V_{GS} = 0\text{ V}$	-	2615	-	pF
C_{OSS}	Output capacitance		-	340	-	pF
C_{RSS}	Reverse transfer capacitance		-	235	-	pF
Q_g	Total gate charge	$V_{DD} = -15\text{ V}$, $I_D = -9\text{ A}$ $V_{GS} = -4.5\text{ V}$	-	24	-	nC
Q_{gs}	Gate-source charge		-	9	-	nC
Q_{gd}	Gate-drain charge		-	8	-	nC

Table 6: Switching times

Symbol	Parameter	Test conditions	Min.	Typ.	Max.	Unit
$t_{d(on)}$	Turn-on delay time	$V_{DD} = -15\text{ V}$, $I_D = -4.5\text{ A}$ $R_G = 4.7\text{ }\Omega$, $V_{GS} = -10\text{ V}$	-	13.2	-	ns
t_r	Rise time		-	93	-	ns
$t_{d(off)}$	Turn-off delay time		-	50	-	ns
t_f	Fall time		-	18	-	ns

Table 7: Source drain diode

Symbol	Parameter	Test conditions	Min.	Typ.	Max.	Unit
$V_{SD}^{(1)}$	Forward on voltage	$I_{SD} = -4.5 \text{ A}$, $V_{GS} = 0$	-		-1.1	V
t_{rr}	Reverse recovery time	$I_{SD} = -4.5 \text{ A}$, $di/dt = 100 \text{ A}/\mu\text{s}$ $V_{DD} = -24 \text{ V}$, $T_j = 150 \text{ }^\circ\text{C}$	-	20		ns
Q_{rr}	Reverse recovery charge		-	16		nC
I_{RRM}	Reverse recovery current		-	-1.6		A

Notes:

⁽¹⁾Pulsed: Pulse duration = 300 μs , duty cycle 1.5%

2.2 Electrical characteristics (curves)



Note: For the P-channel Power MOSFET, current and voltage polarities are reversed.

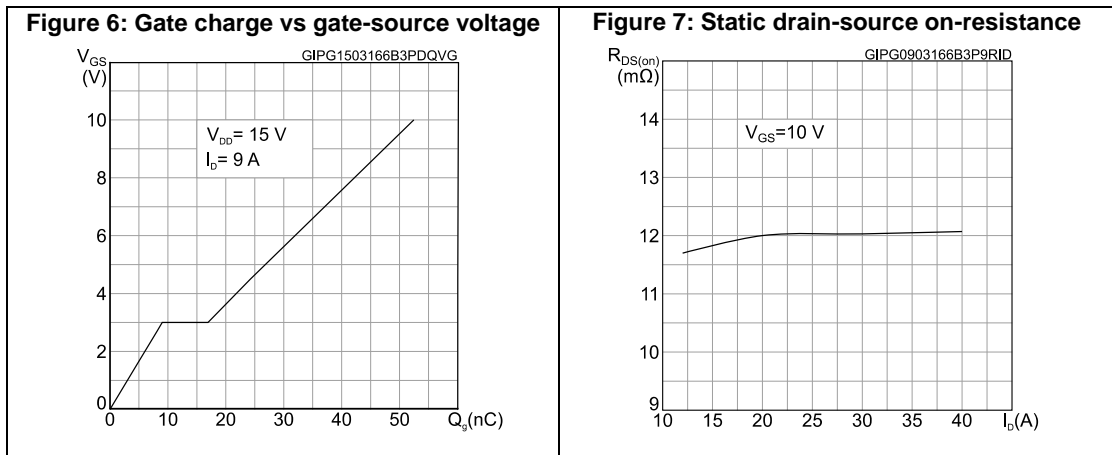
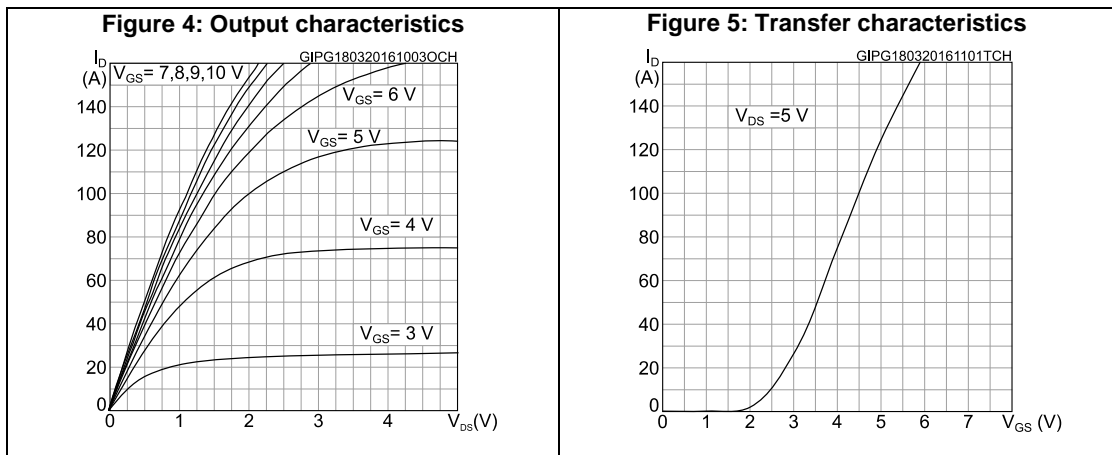
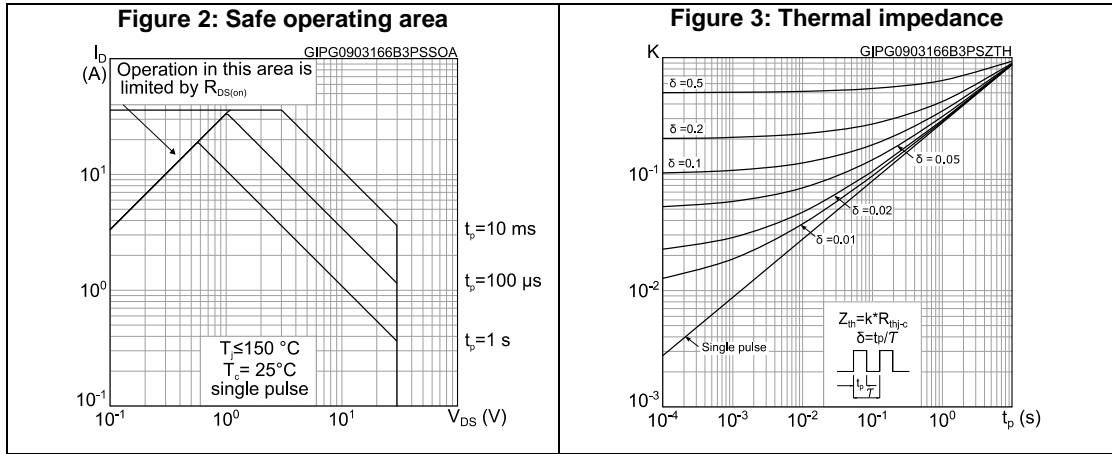

Figure 8: Capacitance variations

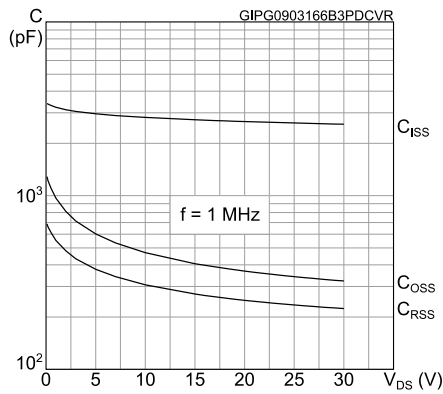

Figure 9: Normalized gate threshold voltage vs temperature

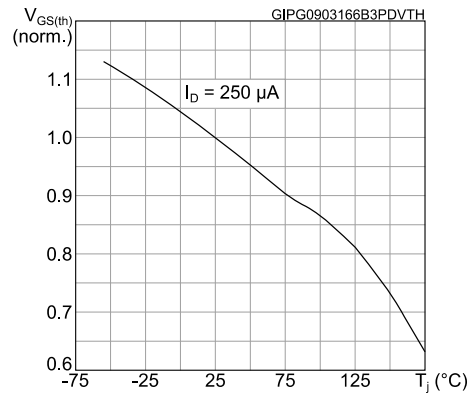

Figure 10: Normalized on-resistance vs temperature

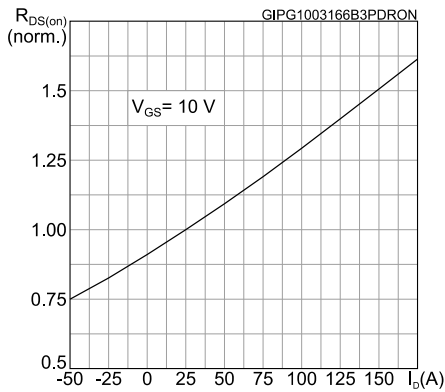

Figure 11: Normalized $V_{(BR)DSS}$ vs temperature

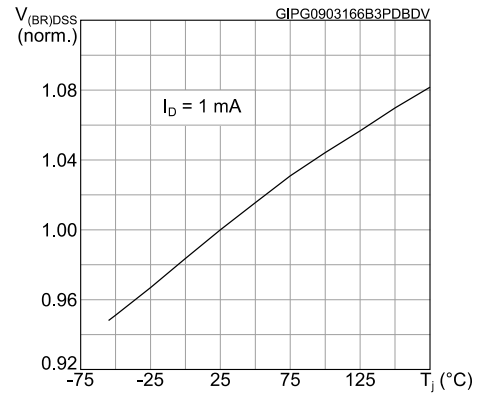
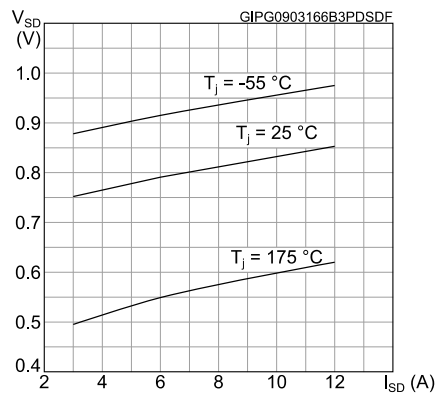

Figure 12: Source-drain diode forward characteristics



3 Test circuits

Figure 13: Switching times test circuit for resistive load

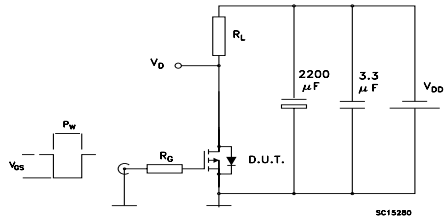

Figure 14: Gate charge test circuit

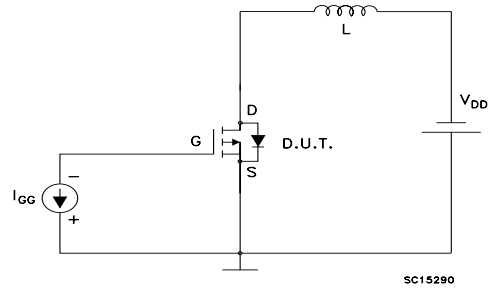
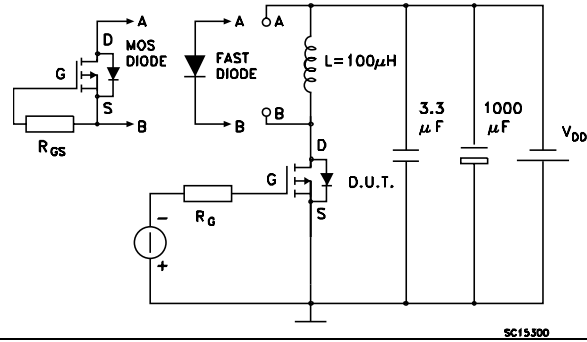

Figure 15: Test circuit for inductive load switching and diode recovery times



4 Package information

In order to meet environmental requirements, ST offers these devices in different grades of ECOPACK® packages, depending on their level of environmental compliance. ECOPACK® specifications, grade definitions and product status are available at: www.st.com. ECOPACK® is an ST trademark.

4.1 SO-8 package information

Figure 16: SO-8 package outline

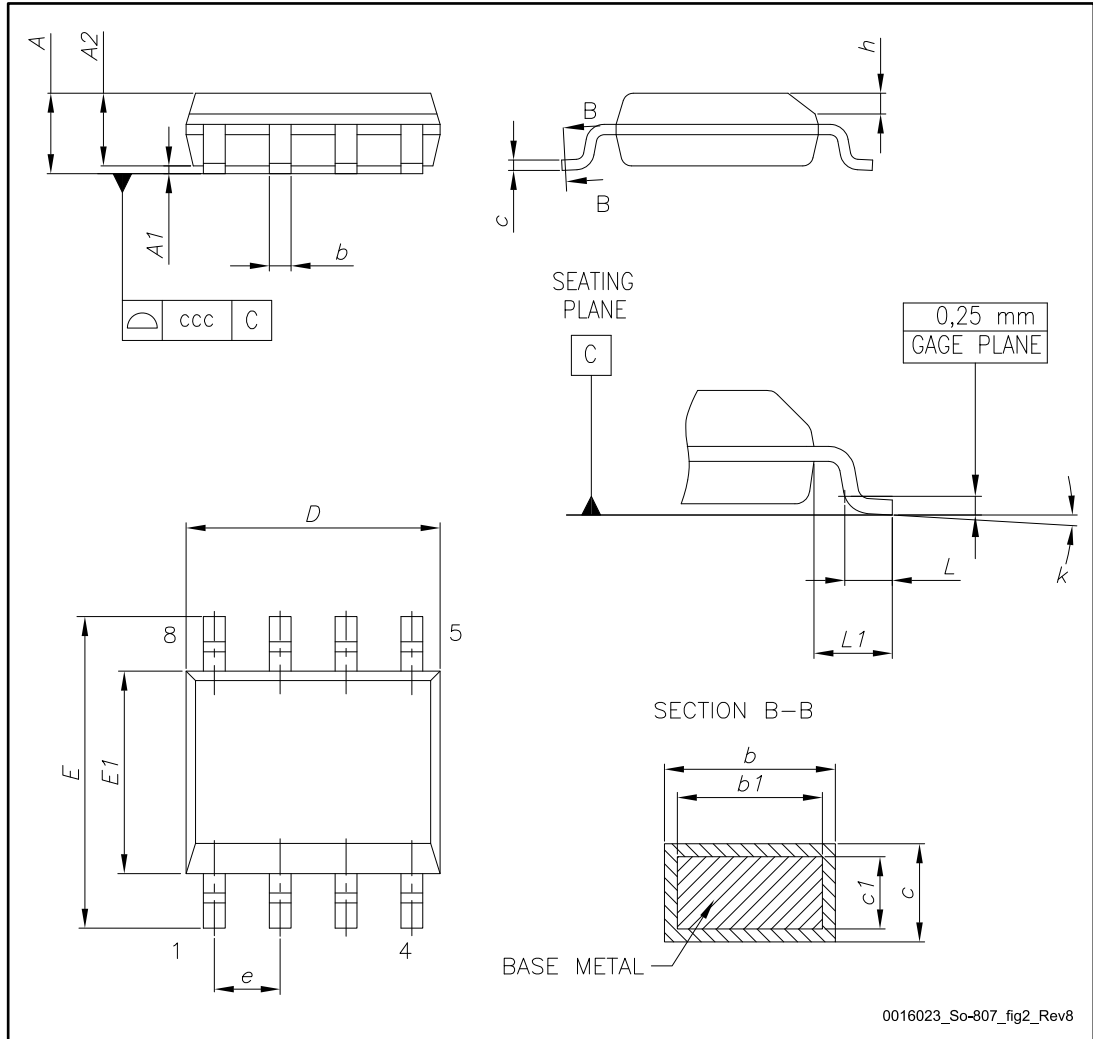
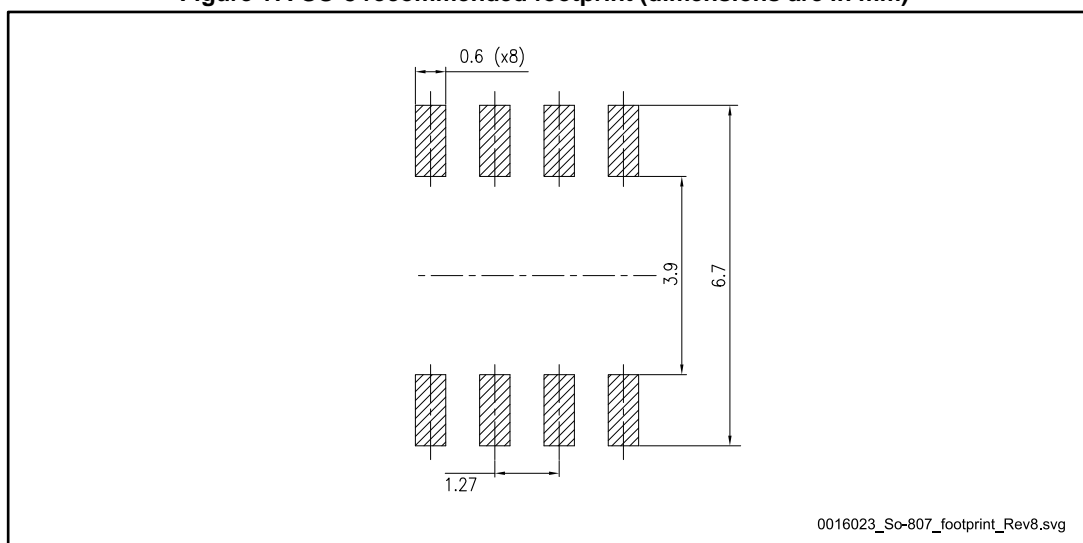

Table 8: SO-8 mechanical data

Dim.	mm		
	Min.	Typ.	Max.
A			1.75
A1	0.10		0.25
A2	1.25		
b	0.31		0.51
b1	0.28		0.48
c	0.10		0.25
c1	0.10		0.23
D	4.80	4.90	5.00
E	5.80	6.00	6.20
E1	3.80	3.90	4.00
e		1.27	
h	0.25		0.50
L	0.40		1.27
L1		1.04	
L2		0.25	
k	0°		8°
ccc			0.10

Figure 17: SO-8 recommended footprint (dimensions are in mm)



4.2 SO-8 packing information

Figure 18: SO-8 tape and reel dimensions

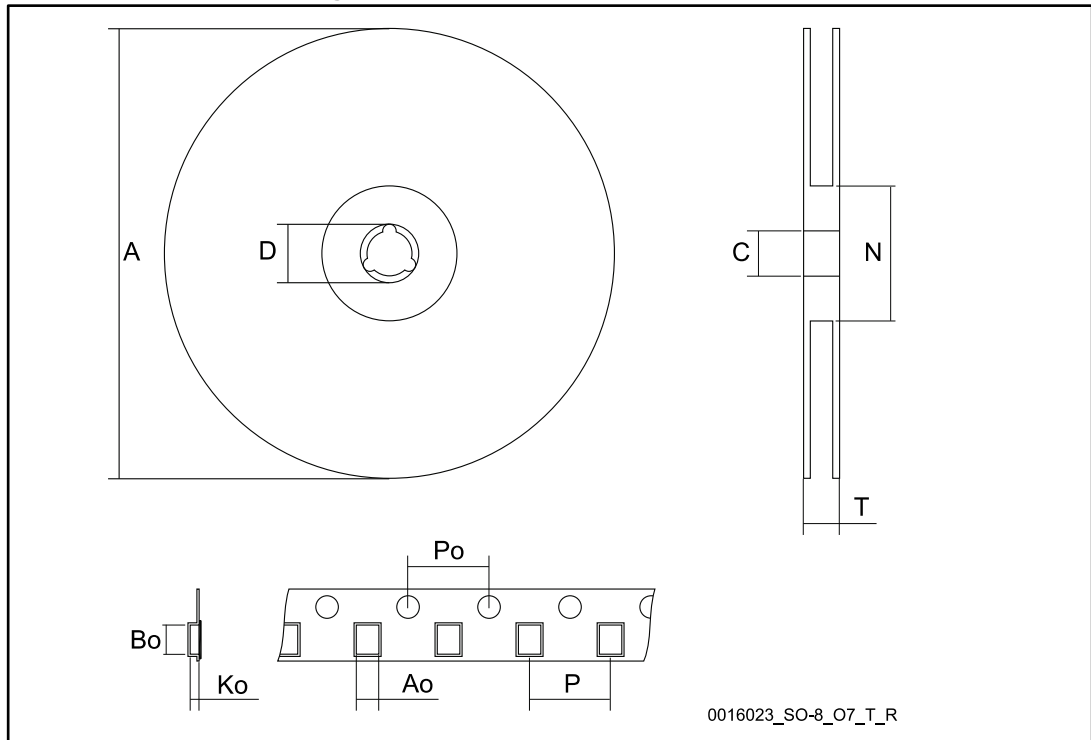

Table 9: SO-8 tape and reel mechanical data

Dim.	mm		
	Min.	Typ.	Max.
A			330
C	12.8		13.2
D	20.2		
N	60		
T			22.4
Ao	8.1		8.5
Bo	5.5		5.9
Ko	2.1		2.3
Po	3.9		4.1
P	7.9		8.1

5 Revision history

Table 10: Document revision history

Date	Revision	Changes
22-Jan-2014	1	Initial release.
15-Mar-2016	2	Modified: title and $R_{DS(on)}$ max value in cover page Modified: Table 4: "On/off states" , Table 5: "Dynamic" , Table 6: "Switching times" and Table 7: "Source drain diode" Minor text changes.

IMPORTANT NOTICE – PLEASE READ CAREFULLY

STMicroelectronics NV and its subsidiaries ("ST") reserve the right to make changes, corrections, enhancements, modifications, and improvements to ST products and/or to this document at any time without notice. Purchasers should obtain the latest relevant information on ST products before placing orders. ST products are sold pursuant to ST's terms and conditions of sale in place at the time of order acknowledgement.

Purchasers are solely responsible for the choice, selection, and use of ST products and ST assumes no liability for application assistance or the design of Purchasers' products.

No license, express or implied, to any intellectual property right is granted by ST herein.

Resale of ST products with provisions different from the information set forth herein shall void any warranty granted by ST for such product.

ST and the ST logo are trademarks of ST. All other product or service names are the property of their respective owners.

Information in this document supersedes and replaces information previously supplied in any prior versions of this document.

© 2016 STMicroelectronics – All rights reserved